

3333 Multi-Use Vertical Pump

Features, Benefits & Specifications

3333 Multi-Use Vertical Pump

Pump Length (feet)	6, 9, 12
Pump Capacity, Maximum	500 GPM (1,892 LPM)
Power Source	Electric; 3, 5, 7.5, or 10 HP
Other Vertical Pump Models	4444, 6000, 6000E, 8000, 8000HP

FEATURES

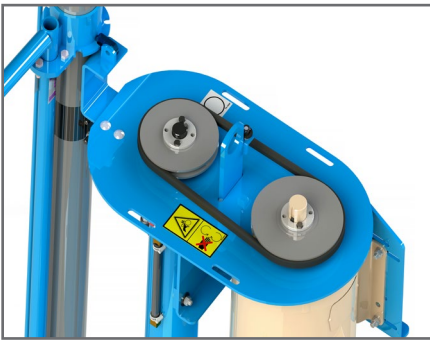

Choose from a selection of electric motors and pulleys to meet your volume output requirements.

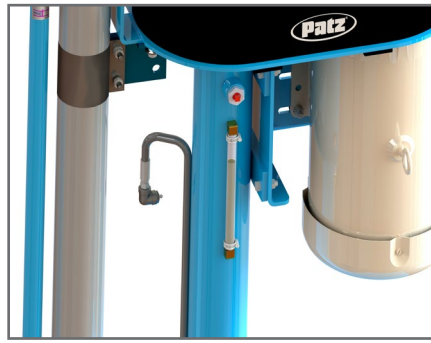

Bearing seals can be purged every 8 hours due to a grease line. A transparent oil line makes reading oil levels simple. A large fill hole makes adding oil easy.

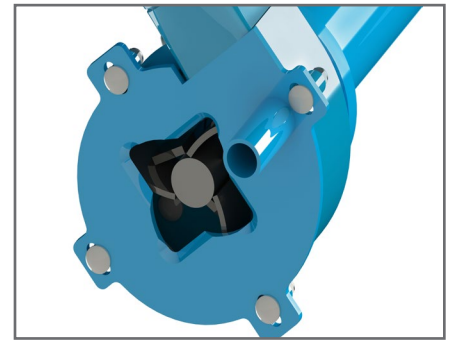

The Shear Plate minimizes clogging. The impeller blades swept-back design increases pumping efficiency. The impeller area is manufactured using heavy, abrasion resistant steel to prevent rust and prolong life.



The Lifting Eye, located on top of the pump, allows the unit to be inserted or removed into the pit easily. It can be used with tractor loader, skid-steer, or winch.

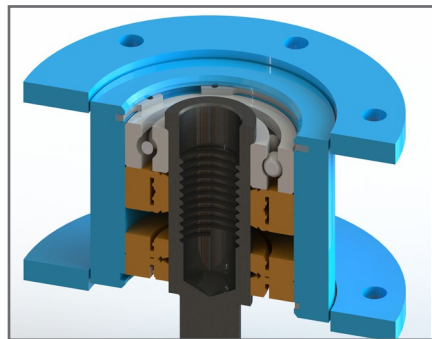

Protection against bearing contamination. The lower bearing's oil-bath chamber has four seals to keep contaminants out.



Optional: A rotating nozzle allows many types of liquid waste to be agitated plus cleanout is improved. Waste can be transferred or loaded while agitating.



CAUTION: Never operate Patz equipment without all shields and guards in place. **Safety Is No Accident.** Before operating any piece of equipment, be sure to read and understand the operator's manual. This manual should be kept with the machine at all times. Additionally, make sure all safety shields and devices are functioning properly and are securely in place. Specifications and prices subject to change without notice.

For some photos in this brochure, guards were removed for photographic purposes only to allow viewing of the equipment features. Before operating equipment, all guards must be in place. Because Patz continually improves and updates products, Patz reserves the right to change the construction of machines or attachments or any part thereof without incurring any obligation to make like changes on Patz machines, or attachments previously delivered. Specifications and prices subject to change without notice.